

Submersible Well Pumps and Water Contamination

A five-year investigation by the Department of Natural Resources and Department of Health and Family Services, Division of Health has determined that certain submersible pumps used to draw water from wells may leak contaminants into drinking water and may pose a health risk.

Contaminants leaked from these pumps come from either mineral oil contained in pump motors or from a dielectric fluid used in the pump motor's capacitor. "Non-food-grade" mineral oils used in some submersible pump motors contained polyaromatic hydrocarbons and other fuel-like compounds. The dielectric fluid in capacitors used in certain pump motors manufactured before 1979 was made of polychlorinated biphenyls, or PCBs.

Depending on its size, a motor may contain from one-half liter to more than 20 liters of oil. Capacitors may contain up to five ounces of PCBs. Small amounts of these substances gradually leak out of submersible well pump motors during normal wear-and-tear. Larger amounts may leak into well water when the pump suddenly fails due to lightning strikes, electrical failures or shorts.

The World Health Organization, International Agency for Cancer Research and the Occupational Health and Safety Administration classify certain non-foodgrade mineral oils as human carcinogens. PCBs are classified as probable human carcinogens by the U.S. Environmental Protection Agency. EPA has established a maximum contaminant level of 0.5 parts per billion PCBs in drinking water.

Human exposure to non-food-grade submersible pump motor oils or to PCBs from PCB-filled capacitors may occur when a person drinks water from these wells. Exposure may also occur when contaminated water is used for cooking, showering or bathing or when contaminated water vapor is inhaled after it is released from steam heat radiators, dish or clothes washers, humidifiers, vaporizers or showerheads.

The Wisconsin Division of Health recommends that as a health precaution consumers should:

- avoid exposure to well water contaminated with submersible pump oils not classified as "food grade" by the U.S. Food and Drug Administration or U.S. Department of Agriculture; and
- avoid exposure to and consumption of water containing PCBs until the PCBs have been eliminated from the water supply, as confirmed by laboratory analysis.

In 1992, the Department of Natural Resources estimated that between 100,000 and 200,000 of Wisconsin's 800,000 wells may contain submersible pump motors filled with oil. Some of these pumps may contain non-toxic, food-grade oil, while others do not. In 1989, an estimated 10,000 to 15,000 oil-filled motors contained capacitors filled with PCBs. More accurate estimates are not available at this time.

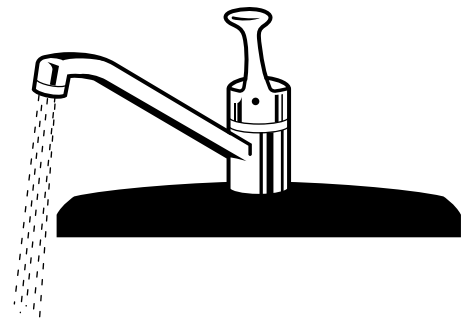



Owners of Submersible Well Pumps Can Guard Against Exposure

Typically, submersible pumps are used for residential wells, rural restaurants, taverns, motels, grocery stores, child care facilities and health care facilities. Larger motors are used in well-water systems serving some subdivisions, condominiums, hotels and motels, shopping malls, hospitals, commercial establishments, schools, industrial facilities, campgrounds and private and public water utilities.

To guard against potential exposure to submersible pump motor oil or capacitor fluids well owners can:

- Determine the manufacturer and model number of their submersible well pump, then contact a state-licensed well driller, pump installer or the DNR to learn whether the pump motor is likely to contain non-food-grade mineral oils, a PCB filled capacitor or both.
- Replace an oil filled submersible pump motor with a water or propylene glycol filled submersible pump motor or with an above ground pump unit if it can be determined, or if it is suspected, that the pump is likely filled with non-food-grade oil. When a contaminated pump is replaced, well owners should clean the well and plumbing system according to the protocol in Appendix C of this document.
- Replace the pump, clean the well and plumbing system, and take drinking water samples for testing by a certified private water testing lab if they know or suspect the pump has a capacitor containing PCBs. Do not use the well if a test indicates PCBs are present above state or federal drinking water standards.

A Wisconsin-licensed pump installer can advise well owners on leak detection, pump replacement, water supply system cleanup and proper disposal of contaminated pumps.

The approximate cost of replacing a domestic submersible pump ranges from \$600 to \$1,200. An accompanying cleanup of the well and/or plumbing system will add to this cost.

Appendices A and B list pump types and models which the Department of Natural Resources has determined may contain non-food-grade oils or capacitors filled with PCBs. The list is not complete, due to the difficulty of finding and confirming information on pumps from the manufacturers. The information on PCBs reflects pumps and motors manufactured after 1960.

A list of state-certified laboratories that can test drinking water samples for the presence of PCBs is included in Appendix D of this document. Well owners also may contact pump manufacturers directly for more information.



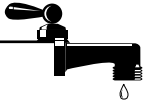

Food-Grade vs. Non-Food-Grade Mineral Oils

The U.S. Food and Drug Administration (FDA) has approved propylene glycol and certain types of mineral oil for occasional contact with or for addition to food products. These oils are commonly referred to as “food-grade mineral oils.”

The Department of Natural Resources has determined that certain submersible pump motors were filled with oil that did not meet FDA requirements for occasional food contact or for addition to food products. These “non-foodgrade” oils are commonly referred to as: transformer oil, heat transfer fluid, refrigerator compressor oil, electrical insulating oils, hydraulic oil, cable oil, spindle oil, agricultural spray oil, turbine oil, and machine or cutting oil.

During a study of a substantial volume of literature, staff from the Department of Natural Resources and Department of Health and Family Services (DHFS) found references indicating that some non-food-grade oils used in submersible pump motors were light naphthenic distillates containing polyaromatic hydrocarbons and long chain aliphatics.

Non-Food-Grade Mineral Oils are Known Carcinogens

Some of these oils have a boiling point, pour point, viscosity and other characteristics that are consistent with refined oils, which have been documented to cause or promote cancer in humans and animals. The World Health Organization (WHO), International Agency for Research on Cancer (IARC) and the Occupational Health and Safety Administration (OSHA) classify certain nonfood-grade mineral oils as human carcinogens.

Though the cancer impacts of these oils usually receive the most publicity, other effects such as reproductive damage, immune system suppression, respiratory distress and other organ damage have been documented in animals and humans exposed to mineral oils.

The Wisconsin Department of Health and Family Services recommends “... that exposure to well water contaminated with submersible pump oils not classified as food-grade by the Food and Drug Administration or Department of Agriculture be avoided. Efforts should be made to minimize the likelihood of such exposures occurring.”

Polychlorinated Biphenyls

The U.S. Environmental Protection Agency (EPA) has designated PCBs as probable human carcinogens. PCBs were banned in 1978 from production or use in the United States. EPA has established a maximum contaminant level (MCL) of 0.5 parts per billion (ppb) for PCBs in drinking water. If PCB contamination is detected in drinking water, people should not drink the contaminated water or use it for showering, bathing, washing or preparing food until the PCBs have been eliminated from the water supply system. Elimination of PCB from a water supply system must be confirmed by laboratory analysis.

Potential Exposure can be Minimized

Potential exposure to non-food-grade oil can be minimized or prevented by replacing an oil-filled submersible pump motor with a water or propylene glycol filled submersible pump motor or with an above ground pump unit. Clean the well and plumbing system according to the protocol in Appendix C of this document.

Oil or PCBs that are released from submersible pumps into wells are groundwater contaminants analogous to fuel oil and other petroleum products.



Submersible Well Pump Designs

Submersible water well pumps are driven by electric motors that are designed to operate under water. There are two basic motor designs for underwater operation.

One design uses special insulation materials on the electrical components of the motor, and the motor housing is filled with clean water or with an antifreeze material called propylene glycol. Water or propylene glycol prevents the entry of dirty or sand laden well water into the motor housing and bearings, preventing premature pump motor or bearing failure.

The second design uses oil in the motor housing to prevent the entry of well water into the motor. If water were to enter into the bearings or into the electrical components, the motor eventually would fail.

An electrical device called a capacitor helps to get a motor started. The capacitor can be located within the motor housing or it can be located in a control panel that is located out of the well and usually in a building.

Before 1979, most capacitors contained Polychlorinated Biphenyl (PCB) dielectric fluid. In 1986 and again in 1989, the Department of Natural Resources published news releases and technical information on the subject of PCB contamination of wells and drinking water from submersible pump motors.

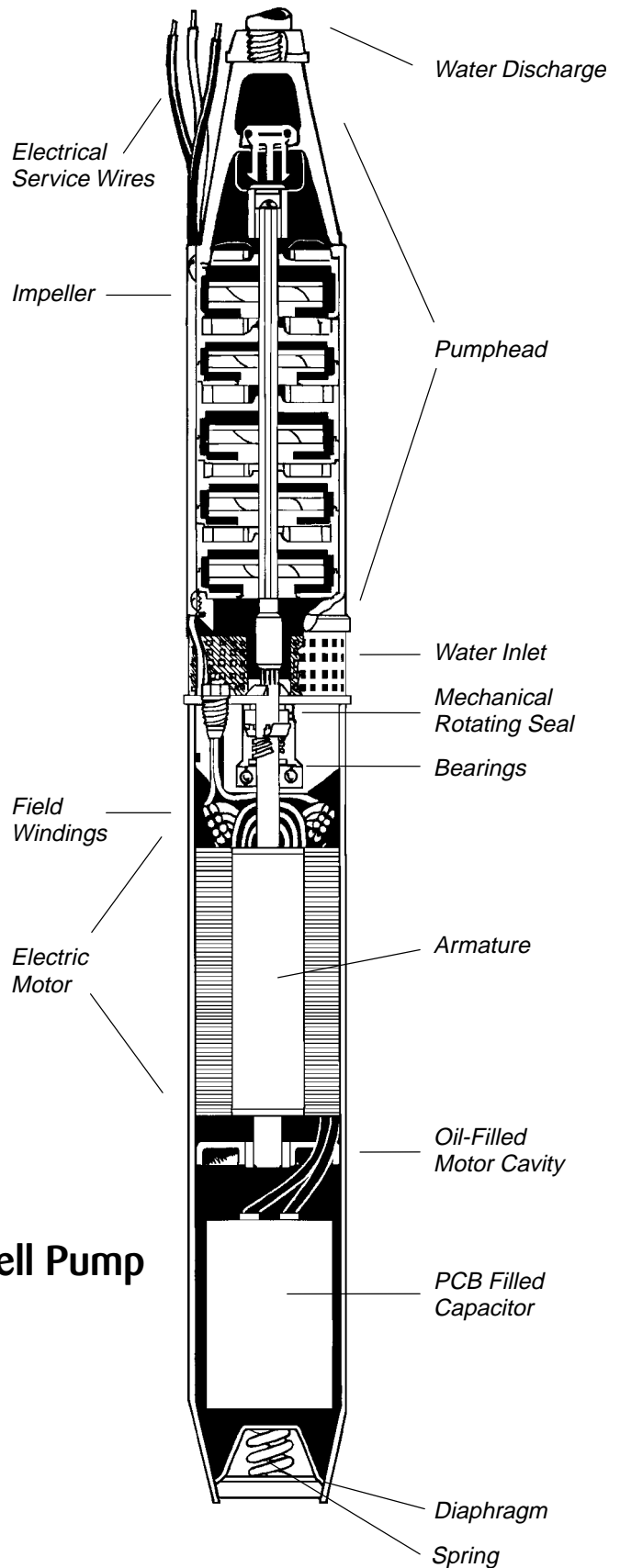

Submersible Well Pump

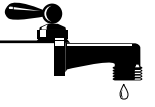

Well Water Contamination

To understand how one might be exposed to oils or PCBs in drinking water, it is important to understand how these materials escape from the motor into the well water.

Oil

On most submersible motors, a mechanical, rotating seal is used to keep the oil inside the motor housing and to keep water out. Springs, diaphragms, centrifugal force and the relative density of the oil are used to make sure that the pressure of the oil inside the motor is slightly higher than the pressure of the water surrounding the motor.

This prevents the water from entering the motor under normal operating conditions, and allows small amounts of oil to seep across the face of the seal to provide lubrication to the seal. Without lubrication, the seal would fail. As a motor continues to function, the bearings, seals and other moving components wear, allowing oil to escape through the seal in increasing quantities.

In addition, corrosion of the motor casing, lightning strikes, electrical failures like shorts in the motor, or other types of catastrophic failures allow substantial quantities of oil to escape from the motor. Escaped oil mixes with well water and is drawn into the pump intake, ending up in the water supply system.

PCBs

PCBs that are on the surface of the capacitor body during pump motor assembly mix with the oil contained in the motor housing. Further, PCBs that migrate from inside the capacitor to the oil in the motor housing also mix with the oil. PCBs are then released concurrently with the oil from the motor housing as previously described.

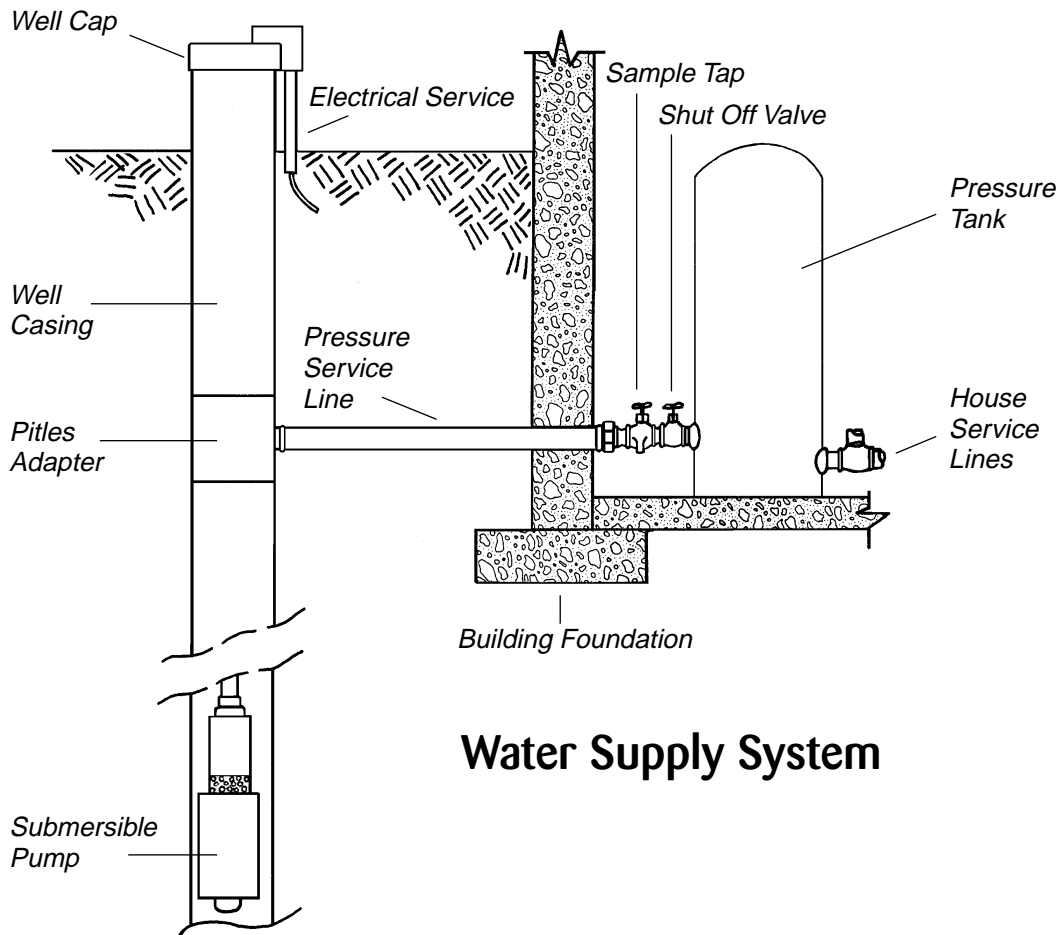

Water Supply System



Human Exposure to Water Contamination from Pump Motors

Human exposure to these contaminants may occur when a person 1) drinks contaminated water (oral exposure), 2) inhales contaminated water vapor released from steam heat radiators, cooking, dish or clothes washers, humidifiers, vaporizers or showerheads (respiratory exposure) and 3) showers or bathes (dermal or skin exposure). The oils of concern form stable emulsions — or are suspended in miniature droplets in a fairly stable state — in water or air and are consequently difficult to see or feel.

Oil

Scientific studies have shown that when certain components of mineral oil are applied to animal skin (epidermis), within minutes measurable quantities of some of the compounds can be found in internal organs. Other scientific studies have shown that mineral oils are not effectively expelled from the lungs. Consequently, mineral oil can remain in the lungs for a longer period of time than other foreign materials.

A mixture of oil and water will be delivered at the tap from a contaminated water supply. The oil may not be visible in the water because it may be in an emulsion with the water. Depending on the type and concentration of oil, a person may or may not notice a petroleum odor.

PCBs

PCBs from submersible pump motor capacitors may mix with the oil contained in the motor housing. Exposure to PCBs occurs when oil containing PCBs leaks into the water supply system.

Both PCBs and mineral oils are found almost everywhere in the environment. However, risk of exposure associated with oil or PCBs in well water can be substantially reduced by removing the submersible pump motor and cleaning the well and plumbing system to remove any remaining contaminants.

Magnitude of the Problem in Wisconsin

Oil-filled submersible motors are used on pumps that serve a variety of facilities. Smaller units are typically used for residential wells, rural restaurants, taverns, motels, grocery stores, child care facilities and health care facilities. Larger units are used for subdevelopment water systems, condominiums, hotels/motels, shopping malls, hospitals, commercial establishments, schools, industrial facilities, campgrounds, private and public water utilities.

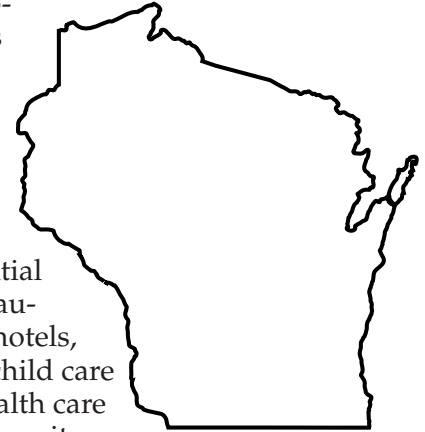

Oil

In 1992, of approximately 800,000 wells in Wisconsin, the DNR estimated that over 100,000 wells may contain submersible pump motors that are filled with oil.

Some of those submersible motors contain food-grade oil as classified by the FDA, while others contain varying grades of oil that do not meet the FDA requirements for a food-grade classification. Available information does not allow an accurate estimate of the number of motors containing each type of oil. Depending on the size of the motor, each motor may contain from 1/2 liter to about 20 liters of oil.

PCBs

In 1989 the DNR estimated that approximately 10,000 to 20,000 of the oil filled motors contained an electrical component called a capacitor, which is filled with PCBs.

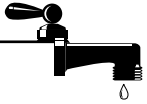

Identifying Oil-filled Pump Motors

A list of submersible motors that are known to contain oil is included in Appendix A of this document. In an attempt to identify which submersible motors are likely to contain FDA approved food-grade oil and which are not likely to contain FDA approved food-grade oil, the DNR has relied on responses from pump manufacturers and laboratory test results.

There are likely other submersible pump brands that used oil-filled motors. Consequently, unless a well owner knows for certain that their submersible pump motor contains FDA approved food-grade oil, it would be prudent to assume the oil is non-food-grade. Your Wisconsin licensed pump installer or well driller may be able to assist you in determining which kind of pump you have. The U.S. Food and Drug Administration has an established analytical method for determining whether an oil meets food-grade criteria.

Identifying Pump Motors with PCB-filled Capacitors

Appendix B of this document provides a list of submersible pump motors known to contain PCBs. Pumps are identified by brand, model and serial number when available.

A list of laboratories certified to conduct PCB analysis is contained in Appendix D of this document. The cost of analysis varies for each laboratory. Some laboratories analyze water samples, some analyze oil samples and some analyze both water and oil samples for PCBs.

There is currently no appropriate field test for analyzing oil.

Replacing Pumps and Cleaning Water Supply Systems

A Wisconsin licensed pump installer can assist you with the pump replacement and water supply system cleanup. Depending on the well and pump size, the cost for a licensed person to replace a domestic submersible pump is estimated to be between \$600.00 and \$1200.00. Costs associated with cleaning a well and plumbing system will vary and are in addition to pump replacement costs.

Information obtained by the Department indicates that by the beginning of 1992, all the manufacturers of small, domestic submersible water supply pumps converted to water or propylene glycol filled motor technology. Therefore, new small domestic submersible pump motors are not likely to contain oil.

Instructions for identifying and cleaning contaminated water supply systems are contained in Appendix C of this document.

The DNR recommends that submersible pump owners who wish to replace their pumps employ licensed pump installers to replace pumps, clean water supply systems and properly dispose of contaminated pumps. The following instructions and those in Appendix C apply to anyone who attempts water supply system cleanup and pump disposal.

Handling and Disposing of Submersible Pump Motors

Residential water supply pumps that are likely to contain non-food-grade oil or PCBs should be handled with care. Avoid direct contact with pumps and pump fluids. Use rubber or plastic (disposable) gloves, protective outer clothing and safety glasses. Use a clay absorbent such as cat litter, oil dry or bentonite to soak up spilled oil.

Oil-filled submersible pump motors that do not contain PCBs can be salvaged and recycled or placed with household waste for disposal.



Pumps Containing PCBs must be Properly Encapsulated

Pumps suspected of containing PCBs require special encapsulation and disposal precautions. The objectives are to prevent inadvertent exposure of people to, or contamination of private property with, PCBs and to prevent possible migration of PCBs to soil or groundwater. Make sure you review the manufacturers' information concerning model and serial numbers to determine if the motor contains PCBs.

After a pump suspected of containing PCBs has been removed from a well, one of the following or comparable encapsulation options should be used to reduce the likelihood that PCBs will contaminate private property or vehicles, or leak from the pump motor into the soil, groundwater, or the landfill:

- Option 1** - Cap one end of a section of metal or PVC pipe, place the pump (motor) inside, fill the remaining space in the pipe with a clay absorbent (kitty litter) and seal the open end with a cap.
- Option 2** - Wrap the pump (motor) in heavy plastic (10 mil), fold the ends of the plastic over the ends of the pump (motor), tape the plastic from end to end with heavy duty plastic wrapping tape, place the wrapped pump in a box, fill the remainder of the box with absorbent material (kitty litter) and tape the box closed with heavy duty wrapping tape.
- Option 3** - Follow the instructions for option 2 except substitute an appropriately sized disposal bag, such as a heavy duty asbestos disposal bag, for the plastic wrap. A shipping box from a new pump may be used to cover the bag. Void spaces in the box should be filled with absorbent material.

Submersible pump motors suspected of containing oil or PCBs may be disposed of at DNR licensed, engineered landfills. A list of those landfills has been included in Appendix E of this advisory document.

Note that any attempt to salvage materials from PCB-contaminated pump motors would subject the salvager to more stringent transportation and disposal regulations.

If the pump head has not been contaminated, it may be removed from the motor, salvaged and recycled. A pump head is contaminated if there is a film of oil on it when it is removed from the well.

Pump motors that are packaged in accordance with options 1, 2 and 3 may be left with the well owner (homeowner) for disposal with their household refuse. If the pump installer takes the motor from the property, it should be disposed of at a licensed engineered landfill within a short period of time.

Motors should not be accumulated by a well driller or pump installer. PCBs are regulated by the Department of Natural Resources. Accumulation of PCB contaminated motors by a pump installer may subject that individual to regulation under PCB management rules.

If the quantity of PCBs requiring disposal exceeds two pounds (approximately 6 pumps), contact a DNR regional solid and hazardous waste specialist. A list of DNR contacts has been provided in Appendix F of this advisory document.

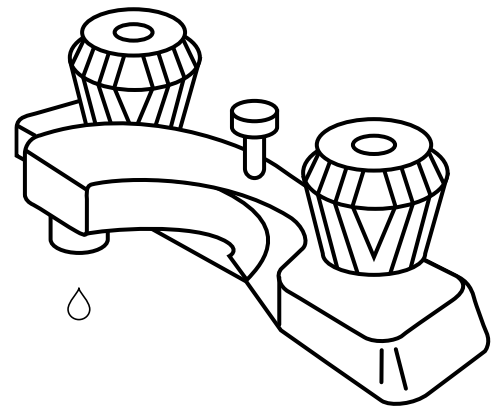

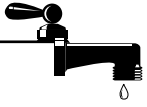

APPENDIX A

Identifying Oil-filled Motors

The following list of oil filled submersible pump motors was compiled from information the Department of Natural Resources obtained from the manufacturers, well drillers, pump installers, technical journals, sales literature, scientific literature, field examination and limited analytical analysis. The list is not exhaustive. Because of the variability of petroleum products and the motor manufacturing process, it is impossible to provide greater accuracy at this time.

It is important to note that in most cases, specific model identification or serial numbers were not provided making identification of specific motor units difficult.

A. O. Smith - Representatives of this company state that their records indicate that oils recognized as food-grade by the FDA were used in submersible pump motors. However, they did not provide any supporting documentation or copies of their records.

Barnes - Also known as Peabody Barnes, Inc., this company was acquired by Burks Pumps, Inc. Representatives of Burks Pumps state that the oils used in Barnes submersible motors was a paraffinic type oil. No documentation was provided to indicate whether the oil used in these submersible pump motors was food-grade. Limited analytical data suggests that oils used in Peabody Barnes submersible motors were not likely food-grade. Montgomery Ward and Johnston Water Systems used motors supplied by Barnes at various times.

Byron Jackson - Currently known as BW/IP International, Inc., documentation was provided indicating that submersible pump motors currently produced by this company contain food grade oil. Documentation indicating whether oils were food-grade was not provided for motors produced before 1991.

Century - Century Electric Motors was previously a division of Transamerica/Delevall, now known as IMO. Century motors were used on many different submersible pump brands including but not limited to Aeromotor, Berkley, Tait, Pumptron, Red Jacket, Rapidayton, Webtrol, Flint & Walling and Teel/Grainger. Century Motors ceased operation in 1986 though many of the brands that used Century motors are still available. Manufacturers who purchased brand names associated with Century Motors have provided documentation indicating that food-grade oil was used

from 1978 to 1986 and state that oil used between 1962 and 1978 was food grade though they did not provide sufficient supporting documentation. Limited analytical data suggests that oil used in at least some pre 1978 motors was probably not food-grade oil.

Exodyne - Exodyne purchased the assets of Magney Electric Motors, Inc. Documentation was provided indicating that submersible pump motors currently produced by Exodyne contain food-grade oil. Documentation for motors produced by Magney Electric Motors before 1991 was not available.

F.E. Myers - Documentation provided by F.E. Myers and analytical data confirm that non-food-grade oil has been used in oil-filled submersible pump motors manufactured by Myers. Between 1981 and 1983, Myers discontinued oil-filled motor production and converted to water filled motor technology. All Myers submersible motors since 1983 use a water filled design.

Fairbanks Morse - Except for pumps utilizing Franklin water filled motors, all motors contain oil. Fairbanks Morse has provided documentation indicating that food-grade oil was used in motors manufactured from 1978 to 1990. Company representatives state that "Information available to Fairbanks Morse is that from 1969 to 1978 an oil which was used was FDA approved and non toxic." Documentation provided by Fairbanks Morse does not indicate that the oil used from 1969 to 1978 was FDA approved, food-grade material. Company Representatives also state that "Before 1969, information available to Fairbanks indicates that the oil used was a white mineral oil which was pharmaceutical-grade and safe

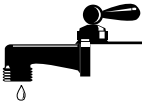

for human contact.” However, Fairbanks Morse provided no supporting documentation or copies of available records.

General Electric - General Electric (GE) indicated that they were not going to review their records to determine what types of oil were used in the various submersible pump motors they manufactured. PCBs have been found in GE submersible pump motor oil, the presence of which require a non-food-grade classification. General Electric motors were used on different brands of submersible pumps. e.g. Hoosier

Red Jacket - Currently, Red Jacket is a division of the Marley Pump Company. Submersible pump motors manufactured by Red Jacket are water cooled and do not contain oil. However, Century Electric submersible pump motors were used on 3,000 of the Red Jacket pumps nationwide between 1978 and 1981. Documentation has been provided indicating that food-grade oil was used in these motors. See the Century Motor section relative to these motors.

REDA, A Camco Company - REDA was previously a division Of TRW. Representatives of REDA state that REDA has not manufactured a submersible pump for use in potable water supply wells since 1979. Documentation has been provided indicating that food-grade oil was used in motors designed for use in potable water supplies from 1965 through 1979. REDA has also manufactured motors for purposes other than potable water supply wells that do not contain food-grade oil. They state that they do not know whether some of these motors may have been installed in potable water supply wells. Prior to 1965, REDA motors contained non-food-grade oil. REDA motors were supplied to various manufacturers during the 1950s including Clayton-Mark, Dempster, Duro, Flint and Walling, Rapidayton, Red Jacket, Rom and Woodmansey.

STA-RITE - Documentation was provided indicating that food-grade oils were used in submersible pump motors manufactured between 1961 and 1966 and from 1975 through 1991. Representatives of STA-RITE state that food grade oils were always used in submersible motors but did not provide sufficient confirmational documentation for motors manufactured prior to 1961 and between 1966 and 1975. However, limited analytical data suggests that food-grade oil was used. STA-RITE also supplied motors to Sears, Roebuck and Company.

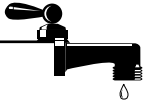

APPENDIX B

Submersible Pump Units that are Known to Contain PCBs

The following manufacturer’s models and serial numbers have been compiled and updated from literature searches and information supplied by pump installers and pump manufacturers. This information represents the best descriptions currently available.

Please be aware that the list is not complete with regard to all manufacturers and brand names and the information has not been confirmed in all cases. Although the list is the best available, its accuracy cannot be guaranteed.

The available information is for pumps manufactured after 1960. Some brands contained PCBs prior to 1960 but did not contain PCBs after 1960.

The following units are those identified as sources of PCB contamination in well water:

Dempster Industries: Prior to 1964, Dempster may have distributed pump units manufactured by REDA and Sta-Rite that may have contained PCB. Use the REDA and Sta-Rite identification data for those pump units.

F.E. Myers: Models SF and SF-2, 2 wire units manufactured from 1964 through 1970 in 1/3 to 1 horsepower and Models SG and S2G, 2 wire units manufactured from 1970 through 1976 in 1/3 to 1 horsepower with date codes prior to 1976 are included. Some S2X models manufactured before 1979 utilized capacitors that contained less than 50 parts per million of PCBs. The date code is located on the motor casing and on a nameplate or tag in the format MMY, e.g., 1177 = November, 1977.

Fairbanks Morse: Two wire units manufactured from 1964 through January, 1979 have a coded alpha numeric date code found on the nameplate. These include the Colonial series and the Chateau series units with date codes of J_, K_, L_, M_, N_, P_, R_, S_, T_, V_, W_, X_, A_, B_, C_, and DA. The blanks are filled with additional characters.

Series	Model Numbers				
Colonial	A2-2507	C2-3306	E2-7509	G2-1009	
	A2-3309	C2-7511	E2-10011		
	A2-5012				
Chateau	A2S-3309	C2S-3306	E2S-7509	G2S-1009	273
	A2S-5012	C2S-5008	E2S-10011	G2S-15012	275
	A2S-7517	C2S-7511	E2S-15015 277		
	A2S-10021	C2S-10014			

Johnston Water Systems: These pumps were manufactured by Peabody Barnes and will be identified as noted under Peabody Barnes. Models include:

V507-31	V513-52	V909-51	VSP913-75	V317-150
V507-32	V523-100	V909-52	VSP909-52	V1306-51
V509-31	V531-100	V913-75	VSP909-51	V1307-52
V509-32	V906-31	V917-100	V1309-75	V1809-100
V513-51	V906-32	V923-150	V313-100	V1813-150

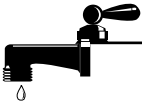

Montgomery Ward: These pumps were manufactured by Peabody Barnes from 1962 to 1972 and will be identified as noted under Peabody Barnes. Models include:

3677A	3679A	3681C	3682E	3684D	24623
3677B	3679B	3681D	3683C	3675A	24625
3678A	3680C	3682C	3683D	3675B	
3678B	3680D	3682D	3684C	3675C	

Peabody Barnes: 2 wire units are identified with the letter “W” as part of the model number, e.g., 409W52. In 1977, an “N” was added to the model number, e.g., 409W52 became 409WN52. The date codes are the last 3 or 4 digits of the coding, showing month, then year of manufacture, e.g., 409WN52-67753-1279 = a 2 wire unit manufactured in December, 1979. Codes are located on a stainless steel band located around the discharge neck of the pump.

REDA: Two wire units have a date code on the nameplate with the format MMY, e.g., 0877 = August 1977. All models listed below with a year code of 79 or less are included. All motors had the serial number stamped on the head of the motor preceded by the 4 digit date code.

41100	42121	43091	7D9P030	4D35P101	14D18P151	312X7P050
41101	42131	43171	7D9P031	6D35P151	17D5P071	314X4P050
41120	42171	43181	9D5P031	7D18P071	17D9P101	320X4P050
42070	42181	43121	9D6P030	10D18P101	23D5P101	32D5P151
42090	42251	43131	9D9P050	12D5P050	23D9P151	
42091		44091	9D9P051	12D5P051		
		44251		12D9P071		

Red Jacket: The capacitor is encapsulated in a plastic housing and the unit is fastened to the bottom of the motor. Although these units are less likely to leak PCB, there are confirmed cases of PCB contamination from Red Jacket pump motors. Motor Models include two wire units with the designations “BV”, “BVC”, “C”, “W” and “RW”, 1/3 through 1-1/2 horsepower. The model designation appears as the first part of the identification number, e.g., BV 300-2 or 50WO-9BC.

The date of manufacturer can be found on the motor housing and on the pump. Codes include:

1968	MC__ and NC__	1973	AH__ through NH__	___ __ __ 78
1969	AD__ through ND__	1974	AK__ through NK__	e.g. 20378 = 2nd week of March 1978
1970	AE__ through NE__	1975	AL__ through NL__	
1971	AF__ through NF__	1976	AM__ through NM__	
1972	AG__ through NG__	1977	AN__ through NN__	

e.g. 3FHR = 3rd week of June, 1973

STA-RITE: Two wire units have a date code on the nameplate with the format MYY. The month is coded as a letter from “A” to “M” and the year as a number, e.g., February, 1977 = B77. Units dated 1979 or earlier are included.

NOTE: Some 3 wire motors with Sta-Rite labels have been verified containing PCB.

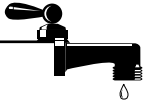

APPENDIX C

Determining If a Water System is Contaminated

The only way to know for certain whether a water supply system is contaminated is to observe oil in the well or plumbing system or to have an oil or water sample from the well or plumbing system analyzed for PCBs. However, there are ways to be reasonably certain of contamination without actually having a sample analyzed. The following procedure will allow an individual to determine if water system contamination is likely:

1. If a pump has been recently removed from or replaced in your well and the pump that was removed looks or feels oily, oil has leaked into the well water, or, there may be an iron bacteria infestation. The water can be tested for iron bacteria to help determine if the oily texture results from oil or from iron bacteria.
2. Appendix B describes the submersible pumps that are known or suspected of containing PCBs. Appendix A describes the submersible pumps that are known or suspected of containing mineral oil and further indicates the current level of knowledge as to whether the oil is a FDA approved food-grade oil, non-food-grade oil or unknown. Try to determine if your pump is on one or both lists, Note whether the pump is on the PCB list, the oil-filled list and whether or not FDA approved food-grade oil was used. Also try to determine if one of the suspect pump units has ever been in the well or if an older pump has ever been replaced. If you can find free oil product in your well or plumbing system, that may indicate that a submersible pump has leaked at some point in time.
3. Check the top of the water in your toilet tanks for an oily film. An oily film may indicate pump motor oil leakage. Proceed with the following steps for confirmation whether you find oil here or not.
4. Obtain a clean, clear glass container. If your hot water heater has a pressure relief valve on the top of the tank, manually open the valve and catch a sample of the water from the overflow pipe in the clear, glass container.

BE CAREFUL! THE WATER IS HOT.

Let the water settle for 30 minutes. If oil is present in the hot water it may float to the surface as evidenced by an oily film as the water cools. The glass may be placed in a refrigerator to accelerate the process. If you do not see oil, proceed with the following steps for further confirmation.

5. Find the electrical control panel and turn off the electricity supplied to the pump. There should be a valve located on a pipe entering or leaving the water pressure tank near the bottom of the tank. Drain the pressure tank taking note of any unusual material that may come out of it. Since oil floats on top of the water, it will likely be the last thing out of the tank. Try to obtain a sample of any oil in the clear glass container. If you do not see or feel oil, proceed to the next step.

Any time that the well or plumbing system is opened or entered, conduct a standard chlorination procedure and take a water sample for bacterial analysis to ensure an uncontaminated system.

To reduce the risks of electrical shock and other hazards and to ensure that the proper tools are available, only a licensed pump installer should carry out the remainder of these instructions.

6. Obtain or construct a top bailer. A top bailer is easily constructed from 2 feet of 1 inch steel pipe threaded on one end, a pipe cap, and a length of clean stout-type cable. Drill a 1/2 inch hole through the pipe wall on the end opposite the threading.

Make sure that any cutting oil used to form the pipe and cap threads has been thoroughly cleaned off the bailer materials. Thread the cap tightly to the threaded end of the pipe. Fasten the cable securely through the 1/2 inch hole at the other end of the pipe.

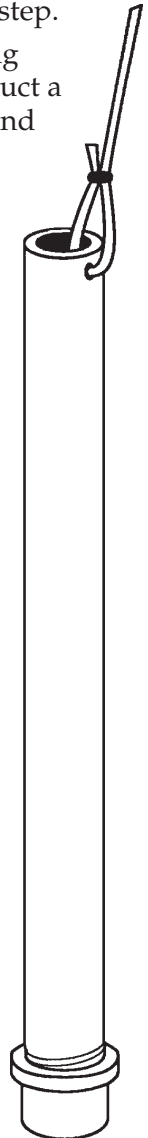

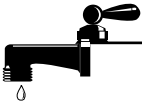

Make sure that the cable is long enough to allow you to lower the pipe to the water level. Tie the free end of the cable securely to a stationary object so that if you lose control of the cable, you will still be able to retrieve the bailer.

Remove the well cap. Lower the bailer slowly into the well until you hear it start to fill. A “ploop, ploop, ploop” sound will let you know that the bailer is filling. It is important to lower the bailer slowly because you want to stop lowering the instant you hear it start to fill. Immediately, before the bailer has time to fill completely, retrieve the bailer.

Empty the contents into the clear glass container and look for oil. If you observe oil, the bailer can be used to bail any remaining free oil product from the top of the water column in the well.

Note: this method will not work if a spool pitless adapter is used in the well. The assistance of a Wisconsin Licensed Pump Installer with the proper equipment to remove the pitless adapter will be required.

Cleaning and Chlorinating the Water System

After having determined that a well needs to be cleaned, and assuming that the old pump has been removed from the well, the following procedure can be used to clean and disinfect the well and plumbing system:

1. Make sure that all of the free oil product has been purged from the top of the water column in the well and from the plumbing system. Pay particular attention to the pressure tank, hot water heater, heating system boiler if applicable, water treatment units such as filters and water softeners, toilet tanks and anti hammer chambers usually located near faucets. If free oil product remains in the system, the remainder of the cleaning procedure is not likely to succeed.

2. Calculate the volume of water in the well. For each 100 gallons of well water volume, mix about 8 ounces of liquid dish washing detergent (not automatic dishwasher detergent) in hot water in a 5 gallon bucket. This ensures that the soap is in solution before it is introduced into the well. Remove the well cap and pour the soapy solution into the well.
3. Thoroughly mix the soap with the water in the well by running a surge block up and down the borehole.
4. Install the new pump and fill the plumbing system with soapy water solution.
5. Add lengths of discharge (drop) pipe to the pump, to place the pump near the bottom of the borehole. Attach a length of hose to the top of the discharge pipe and route the discharge to an appropriate location.
6. Pump the soapy water from the well until it is clear of soap, raise the pump 5 feet and repeat pumping until the water is clear of soap. Continue repeating this procedure as you raise the pump in 5 foot increments until the pump reaches the surface of the water column. You will need to remove lengths of drop pipe as appropriate and reconnect the discharge hose to discharge the soapy water to an appropriate location.
7. Soapy water from the discharge hose may be used to wash down the inside of the casing.

CAUTION: Be careful not to run the water so fast as to deplete the water in the well and run the pump dry. This can be accomplished by monitoring the well water level and adjusting the flow from the discharge accordingly.

8. Reinstall the new pump.
9. Pump fresh water through the plumbing system to purge the soapy water and any contaminants from the plumbing system.
10. Don't forget to take a water sample and get a chemical analysis to confirm whether PCB has been successfully removed from the well and plumbing system.

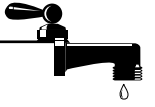

Soapy Water Disposal

Do not discharge soapy, contaminated water within 100 feet of any body of water, drainage way, wetland or in an area where children may play.

Disposal options for soapy water are listed in order of preference below.

1. If a sewer line connected to a wastewater treatment plant serves the residence, all of the soapy water solution should be allowed to drain to the normal sewer line. Let the water discharge until all the soap is purged from the system. You should obtain prior approval from the wastewater treatment plant to discharge the soapy water to their facility.
2. If a tank truck is available, the soapy water may be discharged to the tanker and transported to a local wastewater treatment plant. You should obtain prior approval from the wastewater treatment plant to discharge the soapy water to their facility. The soapy water should be discharged to the tanker until the system is purged of soap. Several tank loads may be needed.
3. Although not the preferred option, the soapy solution may be discharged to a septic system. However, a few precautions are warranted. The amount of water that will be pumped may hydraulically overload the septic system, which may cause sewage to back-up into the residence or the sewage may seep up through the ground surface. This will be temporary, but should be avoided if possible. If the private sewage disposal system utilizes an effluent pump to pump wastewater to the drainage field such as in a mound or a pressure distribution system, the sewage pumps may not be able to accommodate the continuous flow of soapy water. Therefore, you will have to reduce the flow of soapy water accordingly.

4. When no other option is available, the soapy water solution may be discharged through a lawn type sprinkler to an area where people are unlikely to spend a lot of time. Examples include: nearby woods or vacant acreage owned by the well owner.

After the soapy water has been discharged, conduct a normal chlorination on the water supply system to prevent bacterial contamination.

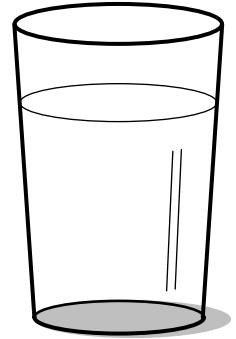



APPENDIX D

Laboratories Certified or Registered for PCBs in Category No: 16

FID	Lab Name	Address	City	State	Zip	Phone #
998027800	.. Quanterra Inc. (Pittsburg)	450 William Pitt Way	Pittsburgh	PA	15238	(412)820-8380
998017130	.. Midwest Laboratories Inc	13611 B Street	Omaha	NE	68144	(402)334-7770
999313040	.. Iowa Hygienic Laboratory	102 Oakdale Campus #H101 OH.	Iowa City	IA	52242	(319)335-4500
999985360	.. ATEC Associates	5150 East 65th Street	Indianapolis	IN	46220	(317)849-4990
999959180	.. CT&E Environmental Services Inc Anatech	1200 Conrad Industrial Drive	Ludington	MI	49431	(616)843-1877
999887790	.. General Engineering Laboratories	PO Box 30712	Charleston	SC	29417	(803)556-8171
999314910	.. CompuChem, Div. of Liberty Analytical	501 Madison Avenue	Cary	NC	27513	(919)379-4100
999819040	.. Professional Service Industries, Inc.	P 4820 W. 15th St.	Lawrence	KS	66049	(913)749-2381
999819810	.. Savannah Laboratories & Environmental	SE 5102 LaRoche Avenue	Savannah	GA	31404	(912)354-7858
999756670	.. IEA Inc. (Schaumburg)	126 West Center Court	Schaumburg	IL	60195	(847)705-0740
999447680	.. Minnesota Valley Testing (MVTL - New Ulm)	PO Box 249	New Ulm	MN	56073	(800)782-3557
999769540	.. Quanterra Inc. (Austin)	5307 Industrial Oaks Blvd #160	Austin	TX	78735	(512)892-6684
998329530	.. Commonwealth Technology Inc. - Lexington	2520 Regency Road	Lexington	KY	40503	(606)276-3506
268201120	.. Advanced Environmental Technical Service	W124 N9451 Boundary Rd.	Menomonee Falls	WI	53051	(414)255-6655
999427000	.. Safety Kleen Corp. (Hebron)	581 Milliken Drive SE	Hebron	OH	43025	(614)929-3532
999054320	.. Safety Kleen Corp. (Smithfield)	3700 LaGrange Road	Smithfield	KY	40068	(502)589-4317
632023810	.. Dairyland Power Coop.- Environmental Lab	3200 East Ave. South	La Crosse	WI	54602	(608)787-1351
405029790	.. WI Public Service Corporation	Central L PO Box 19002	Green Bay	WI	54307	(414)433-1396
113063390	.. Hydrite Chemical - Cottage Grove East	114 N. Main St.	Cottage Grove	WI	53527	(608)257-1414
241329000	.. WI Electric Power Co- Laboratory Services	333 West Everett RM A070	Milwaukee	WI	53203	(414)221-2828
999518190	.. Quanterra Inc. (North Canton)	PO Box 2912	North Canton	OH	44720	(330)497-9396
618026530	.. Waste Research & Reclamation Co., Inc.	5200 State Road 93	Eau Claire	WI	54701	(715)834-9624
999037160	.. OHM Remediation, Analytical Services Div	P.O. Box 551	Findlay	OH	45839	(419)425-6054
999317330	.. RECRA LabNet - Pittsburg	3000 Tech Center Drive	Monroeville	PA	15146	(412)825-9617
999464070	.. Core Laboratories, Inc. (Edison)	284 Raritan Center Parkway	Edison	NJ	08837	(908)225-6753
999472650	.. TriMatrix Laboratories Inc	5555 Glenwood Hills Pky	Grand Rapids	MI	49588	(616)975-4500
999447130	.. NET Inc. (Bartlett)	850 West Bartlett Road	Bartlett	IL	60103	(630)289-3100
999447240	.. NET Inc. (Rockford)	3548 35th Street	Rockford	IL	61109	(815)874-2171
999407970	.. PACE, Inc. (Minneapolis)	1700 SE Elm St. Suite 200	Minneapolis	MN	55414	(612)617-6400
737053130	.. U S Filter/Enviroscan	303 West Military Road	Rothschild	WI	54474	(715)359-7226
632021390	.. Davy Laboratories	115 South 6th Street	La Crosse	WI	54601	(608)782-3130

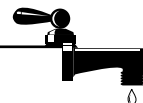

FID	Lab Name	Address	City	State	Zip	Phone #
998047930	.. Weyerhaeuser Analytical & Testing Servc WTC 2F25	Tacoma	WA	98477	... (253)924-6456
998036710	.. American Analytical Inc (A2I)	.. 250 West 84th Dr	Merrillville	IN	46410	... (219)769-8378
721026460	.. Northern Lake Service Inc 400 North Lake Avenue	Crandon	WI	54520	... (715)478-2777
405043870	.. Robert E Lee & Associates PO Box 2100	Green Bay	WI	54306	... (414)336-6338
113138520	.. En Chem, Inc. (Deming Way) 802 Deming Way	Madison	WI	53717	... (608)827-5501
113002230	.. Madison Metropolitan Sewerage District 1610 Moorland Road	Madison	WI	53713	... (608)222-1201
113172950	.. En Chem, Inc. (Science Drive)	... 525 Science Drive	Madison	WI	53711	... (608)232-3300
252021770	.. Cooper Power Systems- Thomas A. Edison Te P.O. Box 100	Franksville	WI	53126	... (414)835-2921
999580010	.. RECRA LabNet - Chicago 2417 Bond Street	University Park	IL	60466	... (708)534-5200
999579460	.. Safety Kleen Corp- Manteuffel Technical C PO Box 92050	Elk Grove Villa	IL	60009	... (773)694-2700
999665920	.. WMX Technology Center Inc. Main Campus 2100 Cleanwater Drive	Geneva	IL	60134	... (630)208-3100
999731810	.. Quality Analytical Labs, Inc. (Montgomery) 2567 Fairlane Dr	Montgomery	AL	36116	... (334)271-1444
999721580	.. LNS Environmental Services Inc 903 North Bowser Suite 230	Richardson	TX	75081	... (800)929-1276
445027660	.. US Oil Company, Analytical Lab 1090 Kennedy Avenue	Kimberly	WI	54136	... (920)735-8295
999869530	.. Triangle Laboratories Inc Box 13485	Research Triang	NC	22709	... (919)544-5729
998310390	.. RECRA LabNet - Amherst 10 Hazelwood Dr	Amherst	NY	14228	... (716)691-2600
268175490	.. Milwaukee Solvents & Chem. (Milsolv) Cor P.O. Box 444	Butler	WI	53007	... (414)252-3550
998202040	.. Kemron Environmental Services (Marietta) 109 Starlite Park	Marietta	OH	45750	... (614)373-2140
999788130	.. Heritage Environmental Services- Indianap 7901 W. Morris Street	Indianapolis	IN	46231	... (317)243-8304
999917270	.. NET Inc. (Cedar Falls) PO Box 625	Cedar Falls	IA	50613	... (319)277-2401
998099190	.. Intertek Testing Services - Dallas	1089 E. Collins Blvd	Richardson	TX	75081	... (972)238-5591
998022410	.. Legend Technical Services 775 Vandalia Street,	St. Paul	MN	55114	... (612)642-1150
998094350	.. Alternative Technologies Inc 12350 River Ridge Blvd	Burnsville	MN	55337	... (612)894-3369
405132750	.. En Chem, Inc. (Green Bay) 1795 Industrial Drive	Green Bay	WI	54302	... (414)469-2436
999989760	.. Horizon Laboratories, Inc. 4463 White Bear Parkway STE105	St Paul	MN	55110	... (612)653-3471
999773830	.. Spectrum Labs Inc 301 West County Road E2	New Brighton	MN	55112	... (612)633-0101
999993060	.. Southern Petroleum Laboratories (SPL) I P.O. Box 31780	Lafayette	LA	70593	... (318)237-4775
998044300	.. Quanterra Inc. (Knoxville) 5815 Middlebrook Pike	Knoxville	TN	37921	... (615)588-6401
999769320	.. Interpoll Laboratories, Inc. 4500 Ball Road NE	Circle Pines	MN	55014	... (612)786-6020
113133790	.. State Laboratory of Hygiene 465 Henry Mall	Madison	WI	53706	... (800)442-4618
241283020	.. Minnesota Valley Testing (MVTL - Oak Creek) 140 E. Ryan Road	Oak Creek	WI	53154	... (414)764-7005
750040280	.. Environmental Task Force UW-Stevens Point,	Stevens Point	WI	54481	... (715)346-3209



FID	Lab Name	Address	City	State	Zip	Phone #
999462640	Braun Intertec Corporation	PO Box 39108	Minneapolis	MN	55439	(612)941-5600
157005530	Badger Army Ammunition Plant (Olin Corp)	1 Badger Road Hwy 12	Baraboo	WI	53913	(608)643-3361
999888890	Environmental Monitoring & Technologies	8100 N. Austin Ave.	Morton Grove	IL	60053	(847)967-6666
999917160	Great Lakes Analytical	1380 Busch Parkway	Buffalo Grove	IL	60089	(847)808-7766
998020430	Specialized Assays, Inc.	P O Box 40566	Nashville	TN	37204	(800)765-0980
999767340	Quality Analytical Labs, Inc. (Redding)	5090 Caterpillar Road	Redding	CA	96003	(916)244-5262
999615430	Quanterra Inc. (Arvada)	4955 Yarrow Street	Arvada	CO	80002	(800)572-8958
998051010	American Environmental Network (AEN-NC)	3000 Weston Parkway	Cary	NC	27513	(800)444-9919
998326010	ACZ Laboratories Inc	30400 Downhill Drive	Steamboat Sprin	CO	80487	(970)879-6590
998355710	American Environmental Network (AEN-CT)	200 Monroe Turnpike	Monroe	CT	06468	(203)261-4458
999071150	Northern States Power Co., Testing Lab	1518 Chestnut Avenue North	Minneapolis	MN	55403	(612)347-9406
471150790	Fort James Operating Co - Neenah Tech Ce	1915 Marathon Ave.	Neenah	WI	54957	(920)729-8004
998044080	Trace Analytical Laboratory	2241 Black Creek Road	Muskegon	MI	49444	(616)773-5998
999871840	Katalyst Analytical Technologies, Inc.	8901 N. Industrial Rd.	Peoria	IL	61615	(309)589-8000
405004600	Green Bay Metropolitan Sewerage District	PO Box 19015	Green Bay	WI	54307	(920)432-4893
998284430	PDC Laboratories Inc	P O Box 9071	Peoria	IL	61612	(309)692-9688

Laboratories Certified or Registered for PCBs in Category No: 18

999462860	National Testing Laboratories, Inc.	556 S Mansfield St	Ypsilanti	MI	48197	(313)483-8333
999871840	Katalyst Analytical Technologies, Inc.	8901 N. Industrial Rd.	Peoria	IL	61615	(309)589-8000
999548330	US Air Force Occupational and Env Lab	Armstrong Laboratory	Brooks AFB	TX	78235	(210)536-3626
998321720	Ann Arbor Technical Services Inc	6540 Jackson Road	Ann Arbor	MI	48103	(313)995-0995
113133790	State Laboratory of Hygiene	465 Henry Mall	Madison	WI	53706	(800)442-4618
999766900	Environmental Health Laboratories	110 South Hill St	South Bend	IN	46617	(219)233-4777

APPENDIX E Wisconsin Engineered Landfills May Accept Wastes Containing Less Than 50 PPM PCBs

Facility	License No.	Activity	Contact	Mail Address	Mail City	State	Zip	Phone	County
Adams County Resource Recovery	03150	LF-Large	Myrna Regal	SW DI 1420 Highway 21	Friendship	WI	53934	608-339-9178	Adams
Brown County East Landfill	02569	LF-Large	Charles Larscheid	2561 South Broadway	Green Bay	WI	54304	920-492-4950	Brown
Dane County LF#2 Rodefild	03018	LF-Large	Gerald J. Mandli SW	1919 Expo Way	Madison	WI	53713	608-266-4029	Dane
WMWI-Madison Prairie LF	03318	LF-Large	Christian D. Johnson	W124N8925 Boundary	Menomonee F.	WI	53051	608-837-9031	Dane
Superior Glacier Ridge Landfill	03068	LF-Large	D. Hank Hechimovich	N7296 Highway V	Horicon	WI	53032	920-387-0987	Dodge
Door County Sanitary Landfill	02937	LF-Large	Harvey J. Matzahn	Co. 1509 Division Road	Surgeon Bay	WI	54235	920-743-4291	Door
Superior City of Moccasin MI	02627	LF-Large	Paul H. King, Admin.	E1407 Hammond Avenue	Superior	WI	54880	715-394-0691	Douglas
Superior Seven Mile Creek Landfill	03097	LF-Large	Alan Albee, General	8001 Olson Drive	Eau Claire	WI	54703	715-839-5096	Eau Claire
Green County Landfill	02990	LF-Large	James M. Hunkins, Man.	W2002 CTH SS	Broadhead	WI	53520	608-897-8605	Green
WMWI-Valley Trail	03066	LF-Large	Todd Hartmann, Gen. Manager	P.O. Box 286	Berlin	WI	54923	920-361-4995	Green Lake
Deer Track Park, Inc.	03230	LF-Large	Stacey M. Thompson, P.E.	N6756 Waldman Lane	Watertown	WI	53094	920-699-3475	Jefferson
Juneau County Landfill #2	03070	LF-Medium	Robert Ciecko, Landfill Manager	W7611 Ceylon Road	Mauston	WI	53948	608-562-5233	Juneau
WMWI-Pheasant Run Recycling	03062	LF-Large	Michael Infusino, D.	19414 60 th Street	Bristol	WI	53104	414-251-4000	Kenosha
Kewaunee County Solid Waste Landfill	02975	LF-Large	Harold Reckelberg	613 Dodge Street	Kewaunee	WI	54216	920-388-4410	Kewaunee
LaCrosse County	03253	LF-Large	Brian Tippets	W1569 State Road 16	Onalaska	WI	54650	608-785-9572	LaCrosse
Lincoln County Sanitary Landfill	03141	LF-Large	Robert Reichelt, Manager	N4750 Landfill Lane	Merrill	WI	54452	715-536-9636	Lincoln
Tenneco Packaging, Inc.-Tomaha	03114	LF-LG-Mono	John Piotrowski, Engineer	N9090 Highway E	Tomahawk	WI	54487	715-453-2131	Lincoln
WMWI-Ridgeview Recycling	03041	LF-Large	Christian D. Johnson	P.O. Box 227	Whitewater	WI	54247	920-732-4473	Manitowoc
Marathon County Landfill ARE	03338	LF-Large	James Pellitteri	S18500B Ringoe Avenue	Ringoe	WI	54471	715-446-3339	Marathon
Wausau Papers County Landfill #3	03115	LF-Medium	Darrell W. Jeffries	P.O. Box 305-Second Street	Brokaw	WI	54417	715-675-3361	Marathon
Wisconsin Public Service Corporation-Weston	03067	LF-LG-Mono	Mark V. Vandenburg	P.O. Box 19002	Green Bay	WI	54307	920-433-4967	Marathon
MAR-OCO Landfill	03095	LF-Large	John Lefebvre	P.O. Box 320	Marquette	WI	54143	715-732-7535	Marquette
WMWI-Metro Recycling	01099	LF-Large	James Dunham, General Manager	10712 South 124 th Street	Franklin	WI	53132	414-529-6180	Milwaukee
Oneida County	02805	LF-Large	Bart T. Sexton, Solid Waste Administrator	P.O. Box 400	Rhinelander	WI	54501	715-282-6003	Oneida
Rhinelander Paper County Landfill	02965	LF-Medium	Jerome T. Neis, Manager	515 West Davenport Street	Rhinelander	WI	54501	715-369-4160	Oneida
Apleton Papers, Inc.-Locks MI	03036	LF-Medium	Scott Heinrich	540 Prospect Street	Combined Locks	WI	54113	920-734-6683	Outagamie
Outagamie County Solid Waste Division Landfill	02484	LF-Large	Gary R. Steede	1419 Holland Road	Apleton	WI	54915	920-832-5277	Outagamie
Consolidated Papers Water RE	01686	LF-LG-Mono	James D. Weinbauer	P.O. Box 8050	Wisconsin Rapids	WI	54495	715-422-3693	Portage
Portage County Landfill	02966	LF-Large	Stefan Fabian, Landfill Manager	1516 Church Street	Stevens Point	WI	54481	715-592-4663	Portage
Fraser Papers, Inc. Landfill	03051	LF-Medium	Jeffrey L. McCulloch	P.O. Box 340	Park Falls	WI	54552	715-762-3231	Price
Kestwall-Hawk Park	00572	LF-Large	Henry A. Koch, General Manager	P.O. Box 081220	Racine	WI	53408	414-844-7080	Racine
Wepeco Caledonia Landfill	03232	LF-LG-Mono	Trent A. Kohl, Project Engineer	P.O. Box 2046-A539	Milwaukee	WI	53201	414-221-2438	Racine
Rock County/Janesville City	03023	LF-LG	John Whitcomb	P.O. Box 5005	Janesville	WI	53547	608-755-3128	Rock
WMWI-Timberline Trail	03455	LF-LG	James S. Scheffer	P.O. Box 160	Bruce	WI	54819	715-868-7000	Rusk
Sauk County Sanitary Landfill	02978	LF-Large	John Carroll, Manager	E8795B Evergreen Lane	Baraboo	WI	53913	608-524-6515	Sauk
Shawano City Phase 2 Landfill	03069	LF-Large	Rick J. Stautz, Director	213 East Green Bay Street	Shawano	WI	54166	715-526-3512	Shawano
Wisconsin Power & Light Edgewater	02853	LF-LG-Mono	Tim Bennington	P.O. Box 356	Sheboygan	WI	53082	920-459-6162	Sheboygan
Vernon County Solid Waste	03268	LF-Medium	Gail Frie, Manager	Route 3, Box 247B	Viroqua	WI	54665	608-634-2900	Vernon
Highway G Sanitary Landfill	03100	LF-Medium	Mark Busha, Facility Manager	Box 938	Eagle River	WI	54521	715-479-2938	Vilas
WMWI-Mallard Ridge North	03244	LF-Large	Michael C. Etnier	West 8470 State Road 11	Delavan	WI	53115	414-724-3257	Walworth
BFI Waste Systems of North America	03144	LF-Large	Tim Goodman	W5987 CTH D	Sarona	WI	54870	715-469-3356	Washington
BFI Waste Systems of North America	03474	LF-Large	Tim Goodman	W5987 CTH D	Sarona	WI	54870	715-469-3356	Washington
Future Parkland Development	03120	LF-LG-Mono	David M. Boyd, President	P.O. Box 702	Milwaukee	WI	53201	414-259-5491	Waukesha
Superior Emerald Park, Inc.	03290	LF-Large	Jean Kramer, General Manager	W124 S10629 S 124 th	Muskego	WI	53150	414-529-1360	Waukesha
WMWI-Orchard Ridge Recycling	03360	LF-Large	Gerard Hamblin	W124 N9355 Boundary	Menomonee Falls	WI	53051	414-251-4000	Waukesha
Wepeco Systems Control Landfill	02887	LF-LG-Mono	Trent A. Kohl, Project Engineer	P.O. Box 2046-8539	Milwaukee	WI	53201	414-221-2438	Waukesha
Waupaca Foundry, Inc. Landfill	03412	LF-LG-Mono	Jeffrey P. Loeffler	311 Tower Road	Waupaca	WI	54981	715-258-6611	Waupaca
Winnebago County Sunnyside Landfill	03175	LF-Large	Henry J. Sommer	100 West County Road Y	Oshkosh	WI	54901	920-232-1800	Winnebago
Wisconsin Tissue Mills North	03275	LF-LG-Mono	Bernie Kopp, Vice President, Technology	P.O. Box 489	Menasha	WI	54952	920-727-3703	Winnebago
Consolidated Papers-Water Quality	02488	LF-LG-Mono	James A. Weinbauer	P.O. Box 8050	Wisconsin Rapids	WI	54495	715-422-3693	Wood
Superior Cranberry Creek	02967	LF-Large	Randy A. Bahl, General Manager	P.O. Box 218	Wisconsin Rapids	WI	54495	715-421-3966	Wood
Wisconsin Tissue Mills	3131		Bernie Kopp	P.O. Box 489	Menasha	WI	54952	920-727-3703	Winnebago



State of Wisconsin Department of Natural Resources

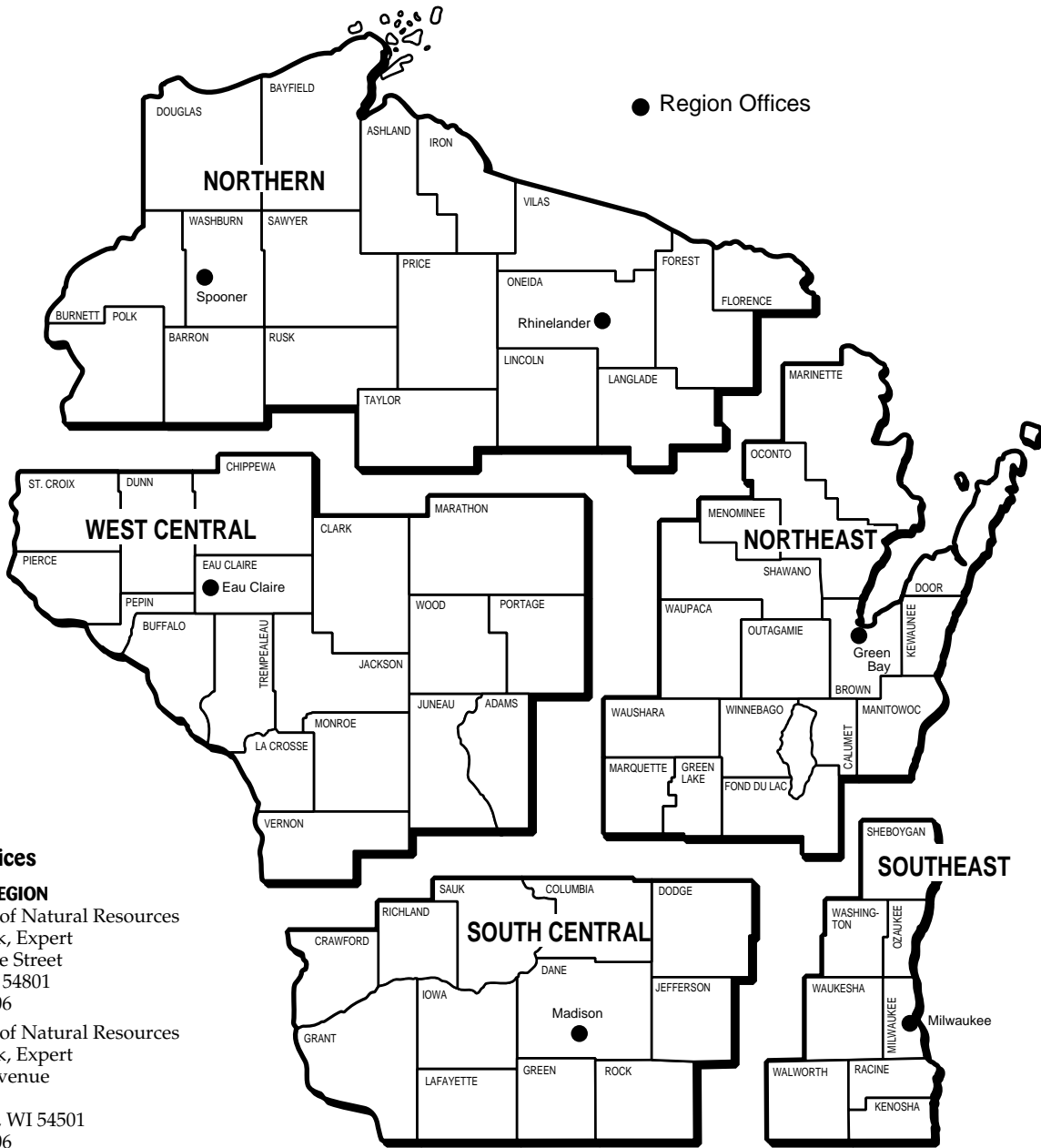

Region Offices

NORTHERN REGION

Department of Natural Resources
 Dave Herrick, Expert
 810 W. Maple Street
 Spooner, WI 54801
 (715) 635-4006

Department of Natural Resources
 Dave Herrick, Expert
 107 Sutliff Avenue
 P.O.Box 818
 Rhinelander, WI 54501
 (715) 635-4006

WEST CENTRAL REGION

Department of Natural Resources
 Larry Schaefer, Expert
 1300 Clairemont Avenue
 P.O.Box 4001
 Eau Claire, WI 54702-4001
 (715) 839-3745

NORTHEAST REGION

Department of Natural Resources
 Bob Barnum, Expert
 1789 Shawano Avenue
 P.O.Box 10448
 Green Bay, WI 54307
 (920) 492-5888

SOUTHEAST REGION

Department of Natural Resources
 Greg Pilarski, Acting Expert
 4041 Richards Street
 P.O.Box 12436
 Milwaukee, WI 53212
 (414) 229-0866

SOUTH CENTRAL REGION

Department of Natural Resources
 Del Maag, Expert
 3911 Fish Hatchery Road
 Fitchburg, WI 53711
 (608) 326-7524

Department of Natural Resources Central Office

Street Address:
 101 South Webster Street
 Madison, WI
 (608) 266-0821

Mailing Address:
 P.O. Box 7921
 Madison, WI 53707-7921

Department of Natural Resources WEB Site

<http://www.dnr.state.wi.us>

Bureau of Drinking Water and Groundwater
Wisconsin Department of Natural Resources
P.O. Box 7921
Madison, WI 53707

B
L
K.
R.
T.

U.S. POSTAGE
PAID
MADISON, WI
PERMIT 906

The Potential for Drinking Water Contamination from Submersible Well Pumps

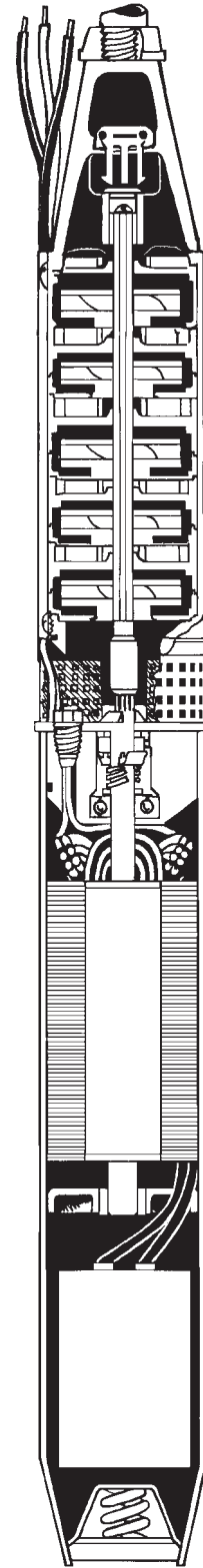

Bureau Of Drinking Water and Groundwater



PUBL-DG-025-98 Rev.

A Note to licensed well drillers, pump installers and other interested parties:

The Wisconsin Department of Natural Resources is providing you with this document to assist you in responding to questions about oils and PCBs in submersible well pump motors.

In a continuing effort to inform the public about possible health threats, the Department of Natural Resources and the Department of Health and Family Services, Division of Health, have in the past released, and will in the future release, information intended to inform owners of submersible pumps about the potential for drinking water contamination from submersible pump motors.

If you have any questions about this document or this issue, please contact your DNR water supply system representative identified on the last page of this document.

The department would like to thank those individuals and firms who have helped provide information and samples that were used to prepare this document.